

Note 1:
Take-off flight path area RWY 06. The obstacles of trees with height from 20 m to 30 m above ground level are situated about 1 800 m from THR RWY 24

Note 2:
Take-off flight path area RWY 24. The obstacles of trees with height from 20 m to 30 m above ground level are situated about 8 800 m from THR RWY 06

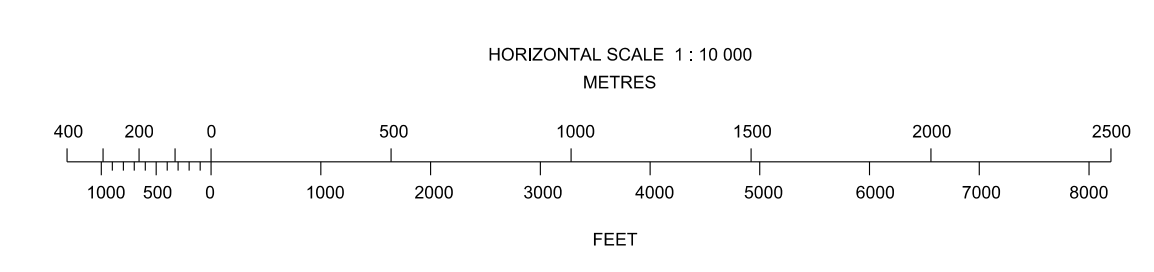

MAGNETIC VARIATION: 1° E 2020
DIMENSIONS AND ELEVATIONS IN METRES


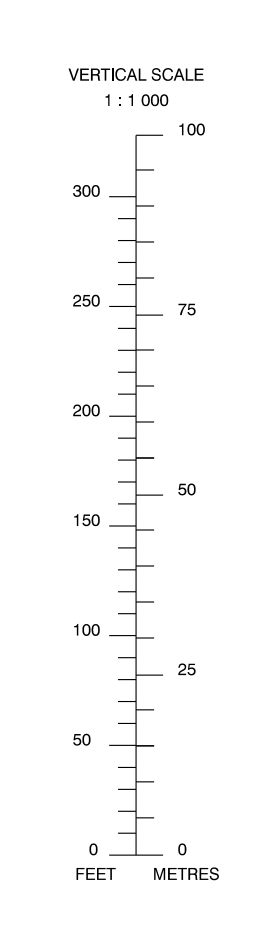

LEGEND

IDENTIFICATION NUMBER	SYMBOL
TREE OR SHrub	(Symbol)
TOWER SPARE ANTENNA	(Symbol)
RAILWAY	(Symbol)
CRANNEY	(Symbol)
CHURCH	(Symbol)
SPRINKLE	(Symbol)
RAIL ROAD	(Symbol)
ROAD	(Symbol)
TRANSMISSION LINE	(Symbol)
CONTOUR	(Symbol)
TERRAIN PREDICTED OBSTRUCTION PLANE	(Symbol)
HYDROGRAPHY	(Symbol)

ORDER OF ACCURACY

HORIZONTAL	1:250
VERTICAL	1:25

AMENDMENT RECORD

NO	DATE	ENTERED BY